



*Metroplus*

### PRODUCT FEATURES :

- Light weight seat.
- Seat design engineered for comfort.
- Seat assembly meets AIS-023 Test Standards/Certified.
- Non metallic parts conform to FR spec IS 15061(Type 2).
- Fixed armrest for better comfort.
- Injection molded parts for aesthetic appeal.
- Customer choices on Upholstery

### OPTIONAL ACCESSORIES (ADDITIONAL COST) :

- 2P seat belt – Static
- Side Armrest
- BR/BC Padding-Round type (30 thk)
- BR/BC Padding-Square type (20 & 40 thk)

### SEAT FITMENT GUIDELINES :

- Use C-Section for seat mounting (25x75x25x2.5mm)
- Use M10x45(Grade-8.8) for mounting a seat leg with Torque -  $50 \pm 2$  NM

### WARRANTY POLICY:

The product covers warranty for manufacturing defects, pre mature failures only. Product abuse & misuse does not warrant any free replacement.

### PERIODIC MAINTENANCE:

Upholstery- Periodic cleaning for dust recommend with vacuum cleaner. Water, liquid cleaners and stain removers should not be used on seats. Dry clean upholstery covers separately.

### ARMREST:

Check the free play for ease of use. Periodically set the recommended tightening torque of  $30 \pm 2$  NM with 13mm flat/ring spanner

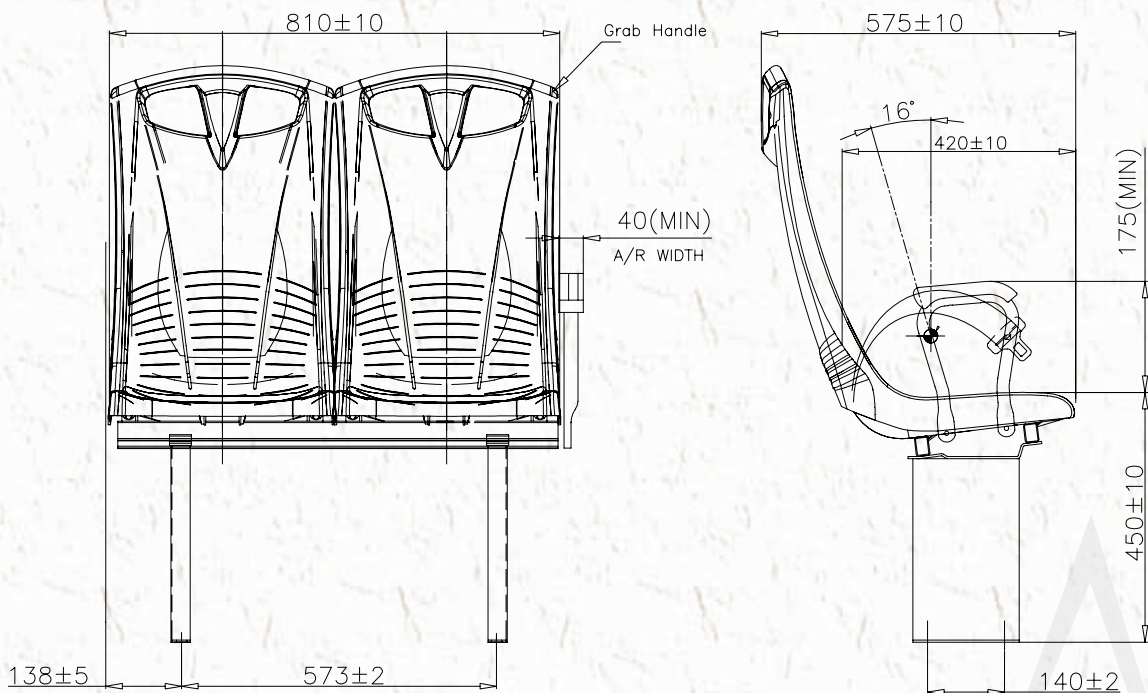

Registered Office & Factory Address

**StellarSP Pvt. Ltd.**

Survey No.449, Anekal - Samandur Road, Samandur Village,  
Anekal Taluk, Bengaluru - 562106, Karnataka, India  
Tel: Factory + 91 80 29909993, Sales: +91 80 22210010  
Mobile: Marketing + 91 91410 45275, Sales +91 91410 45276  
Engineering +91 91410 45280, Purchase +91 91410 45288  
Email: [contact@stellarsp.com](mailto:contact@stellarsp.com), [sales@stellarsp.com](mailto:sales@stellarsp.com)  
[www.stellarsp.com](http://www.stellarsp.com)

### SEAT DIMENSIONAL SPECIFICATION

Sl. No	Description	Seat Size (No. A/R)	
		MM	INCH
1	1S	$410 \pm 10$	16
2	2S	865/810	34/32
3	3S	-	-
4	5S	-	-